

**Cayman Islands Public Lands
Commission**

Seven Mile Public Beach Park Vendor Policy

Updated April 2023

Preface

The purpose of this policy is to act as an operational guide for the Members of the Public Lands Commission (the “Commission”) for the acceptance and processing of applications and the overall management of vendors on the Seven Mile Public Beach.

The goal of which is to facilitate the public’s access to a prominent section of the Seven Mile Public Beach system with the organized provision of food, beverages, and ancillary services.

Contents

Contents

Part A: Objectives and Statutory Guidelines	4
1. Objectives.....	5
2. Statutory Guidelines.....	6
3 Situations where the Seven Mile Public Beach facility can be used without a Permit	8
Part B: Seven Mile Public Beach Park Zones and designated areas for Commercial Vending.....	11
4 Seven Mile Public Beach Park Zone Map	12
5 Typical Vendor Categories and Applications.....	13
5.1 Categories	13
5.2 Items to Note related to Operations:.....	14
6 Vendor and Non –Vendors Applications.....	15
6.1 Powers of the Commission.....	15
6.2 The Commission also has the right to deny, suspend, revoke.....	15
7 Food Handling Safety for Food Stalls and Food Carts.....	16
8 Lifeguard Certification (inclusive of CPR/ First Aid).....	17
9 Health and Massage Vendors.....	17
10 Vendor Locations and Number of Intended Vendors.....	17
10.1 Vendor Kiosks	18
10.2 Current state of Kiosks.....	18
10.3 Items to be rectified by Government.....	19
10.4 The Proposal.....	19
10.5 Survey of Kiosk area	20
10.6 Allocation of collapsible tents based on space between kiosks.....	21
11 Food and Juice Trucks Area.....	23
12 Outdoor Food Court Area.....	24
13 Food Stalls, Food Carts and Local Produce.....	25
14 Beach Chair and Watersports vendors.....	30
14.1 The Proposal.....	35
15 Evaluation Criteria of Vendor Applications.....	40
A. MANDATORY ELIGIBILITY REQUIREMENTS (for Vendors)	40
B. CONDITIONAL REQUIREMENTS UPON APPROVAL.....	41
C. RATED CRITERIA	42

Part A: Objectives and Statutory Guidelines

1. Objectives

The overarching objectives of this policy are as follows:

1. To provide a balanced use of the beach for Caymanians, other residents, and visitors.
2. To have orderly engagement of visitors on the beach by vendors.
3. To have vendor opportunities filled by small or micro business establishments.
4. To have vendor performance evaluated and managed.

Primary beach use objectives for Caymanian and other residents are:

- a. To enjoy the beach for swimming, sunbathing and picnics.
- b. To enjoy sunsets and sunrises with views out to the water.
- c. To enjoy beach walks with unrestricted access along waterline.
- d. To enjoy informal activities on the beach such as sports, exercise, or events open space to play games, race, skip rope, and host activities near to cabanas, etc.
- e. To enjoy the use of the sporting facilities on site and attend organised events.

Primary beach use objectives for Visitors are:

- a. To enjoy a pristine beach on Grand Cayman.
- b. To have easy access to the water.
- c. To have access to shade.
- d. To have access to food and beverage (snacks, lunch, etc.)
- e. To have limited haggling by vendors attempting to sell services or wares including taxi and bus drivers.
- f. To have a location on the beach to store their personal belongings without fear of theft.

2. Statutory Guidelines

The statutory guidelines for the Commission are found in Section 9 and section 14 through 21 of the Public Lands Act (2020 Revision) and reads as follows:

Posting signs and advertisements

9. The Commission may post such signs, notices and advertisements, and distribute such other information to the public, as it considers necessary in order to promote public knowledge of and compliance with this Law and to support the administration of this Law.

PART 3 - USE OF PUBLIC LAND

Right of public to use public land

14. Public areas of public land are open for use by all members of the public without discrimination on the basis of race, gender, age, colour, language, religion, political or other opinion, national or social origin, association with a national minority, sexual orientation or physical or mental impairment, property, birth or other status.

Carrying on a commercial activity on public land

15. A vendor who wishes to carry on a commercial activity on public land must submit an application or a tender document to the Commission for a vendor's permit in respect to each location where the commercial activity will take place, in the form, and including the information, required by the Regulations.

Granting a vendor's permit

16. (1) The Commission shall review, within the prescribed period, an application or tender document submitted under section 15 and may either —

- (a) subject to subsection (2), grant a vendor's permit to the applicant for such term, not exceeding two years, as the Commission considers advisable; or
- (b) refuse to grant a vendor's permit.

(2) On payment of the proper fee and any penalties owed by the applicant under this Law, the Commission shall issue the vendor's permit, subject to any terms and conditions that it deems necessary in order to minimize public disturbance or to protect public land.

Renewal of vendor's permit

17. (1) A vendor who wishes to renew their vendor's permit shall apply to the Commission for renewal at least three months before the date of expiry of the permit.

(2) The Commission shall review an application for renewal submitted under subsection (1) and may, before the expiry of the vendor's permit —

- (a) renew the permit on such terms and conditions as the Commission sees fit;
- or

(b) refuse to renew the permit.

(3) The Commission shall notify the applicant in writing of the renewal or refusal to renew and give reasons in writing where the renewal is refused.

Late application for renewal

18. (1) The Commission may accept an application for renewal of a vendor's permit submitted after the deadline referred to in section 17(1), provided that it is submitted before the date of expiry of the permit.

(2) Where the Commission receives an application submitted after the deadline referred to in section 17(1) —

(a) the Commission shall send a notice to the applicant indicating whether or not it accepts the application for consideration; and

(b) the Commission may impose, in addition to the permit fee, a prescribed penalty for each day after the deadline referred to in section 17(1) that passes before the application is submitted.

Deemed extension of vendor's permit

19. If the Commission does not provide an applicant for renewal with the notice required under section 17(3) or 18(2)(a) before the day on which the applicant's permit expires, the vendor's permit is deemed to continue to be valid until such day as the applicant receives notice from the Commission that the application is granted or refused.

Public display of permit

20. A vendor's permit granted or renewed under this Law shall be evidenced by a certificate in the prescribed form, which must be publicly displayed by the vendor on the premises to which the permit relates.

Cancellation or suspension of vendor's permit

21. The Commission may suspend, cancel or refuse to renew a vendor's permit if it determines that the vendor has contravened this Law, the Regulations or the terms and conditions of that person's vendor's permit.

Other sections of the Public Lands Act (2020 Revision) may apply as well as the Procedures Manual.

Paragraphs of the Public Lands Regulation (2021 Revision) apply to the Public Access to Public Land, Traffic Control, Recreational Activities, Prohibited Conduct and Behaviour, Protection of Public Lands, Commercial Activities and Organized Events, Permits, General provisions and Ticketable Offences.

3 Situations where the Seven Mile Public Beach facility can be used without a Permit

Use of public land without a permit are allowed under certain conditions and within times of openings and closures. Permits or restrictions typically apply for any uses that are not stated in the Public Lands Act or Regulations. The following are typical uses that are possible without a permit.

Organized Events

- Any event to be attended by 25 people or less.
- A permit is also not required for the following organized events:
 - a tour group that stops on public land or at a facility for touring, sightseeing or a picnic;
 - a school group on public land for an educational purpose;
 - a marriage ceremony;
 - a national event;
 - a political meeting;
 - a religious organization or church;
 - a group carrying out activities on public land in the public interest, such as cleaning up or maintaining beaches;
 - an event organized by a registered non-profit organization for the purposes of charity fundraising; or
 - a one-time non-profit fundraising event which does not require registration under the Non-Profit Organisations Act (2020 Revision).

Boats, vessels (including motorized personal watercraft and the like)

- Only for the loading or unloading the boat or vessel on the beach is permitted within the designated channel areas.
- Solicitation of trade and business without an approved vendors permit and within the designated vendor areas is strictly prohibited.
- Swim areas are to remain clear of boating traffic in line with Port Authority and law enforcement guidelines.

Recreational Activities

- A person may engage in games or recreational activity provided that:
 - they do not contravene a prohibition or rule on a sign posted; and
 - they do so in such a manner where they do not subject any other person not engaged in the game or activity to a substantial risk of injury, without the other person's consent; and
 - they do so in such a manner where they do not expose a facility or property to a substantial risk of damage.

Vehicles

- Motorized vehicles are not allowed except within designated access and parking areas, or short-term access granted by the Commission and the manager of the facility.
- If other motorized vehicle designations are made by the Commission signs are to be posted and followed.
- The use of pedal bicycles, skateboards, scooters, rollerblades or other non-motorised means of transport on public land is allowed in accordance with any posted traffic signs and traffic control measures.

Camping

- A person who is legally and ordinarily resident in the islands may camp without a permit on public land in the following circumstances:
 - for a period not exceeding five consecutive days if not connected to a public general holiday or Easter; or
 - on a public general holiday, and for a period of seven days prior to, or seven days following, a public general holiday; or
 - for a period of ten days prior to Good Friday, or for a period of ten days ten days following Easter Monday, or a period of time prior to Good Friday and following Easter Monday, where the total period does not exceed ten days.
- If designated camping sites are indicated camping will occur in those areas.

Barbequing and Fires

- A person can maintain a cooking fire on public land provided that it is in:
 - A public barbeque facility; or
 - A personal portable barbeque or fire pit; or
 - A personal portable stove.
- A person shall not leave an open fire or live coals unattended in a picnic area or other area on public land.
- Bonfires and Open Fires on public land require a permit

Control of Animals

- A person in charge of an animal shall not bring or allow the animal to be on public land unless—
 - The animal is on a leash or lead or in a cage;
 - The animal is at all times entirely within the control of the person; and
 - While on the respective public land, the person immediately cleans up, removes and disposes of the animal's defecation.
- A person in charge of an animal shall not bring or allow the animal on any athletic playing area, children's playground area or in any facility unless the Commission or the manager

of the facility has posted a sign permitting the animal to be there.

- A person in charge of livestock shall not bring or allow livestock to enter this site unless the Commission and the manager of the facility has posted a sign permitting the livestock to be there.

Signage

- A person or political party who is nominated as a candidate for a general election of members of the Parliament under the Elections Act (2021 Revision) may erect election signage without requiring a permit under this regulation for the period commencing on the date of nomination and ending on the date of election as determined by the Elections Act (2021 Revision).
- Any sign, billboard or other marketing material may only be erected in accordance with the terms and conditions of a permit or approval of the Commission.

Under Regulation 26(3)(b) the fees set out in Schedule 1 are as follows:

PERMIT FEES

Type of permit	Regulation	Fee
1. Operation of motorised vehicle off road	7	\$100 per vehicle
2. Docking, etc. of boat or vessel	9	\$250 per vessel per use
3. Horse riding	12	\$650 annual, per stable
4. Camping	13	\$200 per tent
5. Bonfire or open fire	16(2)	Nil
6. Temporary structure	19	Nil
7. Organized event	24(1)	26 – 100 persons - \$100 101 – 250 persons - \$200 251 – 999 persons - \$500 1000 persons or more – \$1000 per every thousand persons
8. Vendor's permits	28(b)	kiosk/land – \$75 per annum local farm produce – nil watersports/public dock/ramp – \$250 per boat per annum \$50 per jet ski per annum \$250 per floating device per annum

OTHER FEES

Application Type	Fee (non-refundable)
Non-Vendor Application Fee	\$50
Vendor Application Fee	\$100

Fees can be paid at any Post Office (Cash transactions accepted) or the Public Lands Commission Inspectorate Office (Credit or Debit card transactions accepted).

Part B: Seven Mile Public Beach Park Zones and designated areas for Commercial Vending

4 Seven Mile Public Beach Park Zone Map



Legend

Zone	Description	Zone	Description
WS 1	North Watersports Zone	BF	Beach Football sand pitch
WS 2	South Watersports Zone	FC	Outdoor Food Court Area
BC 1	North Beach Chair Zone	FS	Food Stalls and Local Produce
BC 2	South Beach Chair Zone	FT	Food Trucks Area
No Vending	No Vending Zone (left clear)	Parking	Main Parking Lot
BR 1	Southern Public Restrooms	PG 1	Kids Play Area
K 1	Vendor Kiosks	Green 1	The Main Green
Green 2	Southern Lawn Area	CAL	Calisthenics Park
		VB	Volleyball Courts

Map zones and legend are to be used in small scale representations for wayfinding but where possible the actual zone names are to be directly integrated into the map at larger scales.

5 Typical Vendor Categories and Applications

5.1 Categories

The following are the designated categories of trade and examples of intended products and services for the Seven Mile Public Beach Park vendors:

Vendor Category	Description of Intended Sale or Service Items	Alignment with Trade and Business Act
Beach Lockers	Locker rentals for storage of personal effects	Retail
Beach Gear	Beach chairs rentals Umbrellas Towels	Retail
Watersports	Personal Watercraft (Limits may be placed on active quantities) Paddle Boards Snorkel Equipment Electric Surfboards, etc. (Other water sport opportunities that are a desired fit may be allowed. Some water activities may be subject to consultations or approvals by the Port Authority, Coast Guard, law enforcement, etc.)	Watersports (Rentals only)
Beverages	Nonalcoholic drinks, Soft drinks Water Ice, etc.	Retail (Sale of Alcohol shall only be permitted in occasional circumstances and requires the issuance of a Liquor License.)
Sundry and Cultural Wares	Cayman cultural and local wares (e.g. thatch and wooden products, etc.) Environmental and sustainable focused goods (e.g. plastic replacement products) Hats, flip flops, tote bags, beach cover ups, Sunscreen (environmentally sensitive), Candies Souvenirs Tee Shirts, wraps, sunglasses, etc.	Retail
Beauty and Massage	Hair Braiding Massages	Beauty and Massage
Food and Juice Trucks	Food and juices offerings are to be choreographed by the Commission. (Ice Cream trucks form part of this category)	Restaurateur

Food Stalls and Food Carts	Local Cuisine Jerk BBQ and Grilled Food Grillers (Hamburgers and Hotdogs), etc.	Restaurateur
Local Produce	Coconuts Mangos Jams and Jellies Etc.	Exempt (under Agriculture Products and Cottage Industry if it meets the definition of the Act)

5.2 Items to Note related to Operations:

- a) Vendor Permits for trade at this site may be issued in the first instance as a provisional permit allowing an applicant to achieve compliance with other relevant legislation prior to trading. If this site is to be the sole place of conducting business for a vendor they should receive conditional permission to vend from this location first prior to receiving a Trade and Business License.
- b) It is the intent of the Commission to promote and encourage small business development at this location. Micro Businesses and Cottage Industry applicants are to be considered.
- c) Value add items such as Wifi and other cursory services shall not be limited to a specific category due to the assistance they provide to commercial transactions. A vendor's actions or services shall also not bind the Government however in the provision of any service that it deems in the public interest.
- d) Sale of Alcohol on public land is prohibited except in accordance with the terms and conditions of a vendor's permit. The Commission may issue occasional permits at this site allowing vendors to sell alcohol at their discretion. This prohibition extends to chargeable events where alcohol is provided or allowed to be brought because of a cover fee.
- e) Any structure for which the Crown owns and where it is a condition that the vendor be located within or identified with that structure shall be used in accordance with the vendor's permit.
- f) Visiting food trucks inclusive of Ice cream trucks and sale of food from personal vehicles will be prohibited at this site without first receiving permission from the Commission.
- g) Littering by any vendor is strictly prohibited. All vendors are to promote that their patrons use this site responsibly and provide waste and recycle bins for their patrons to use. Vendors are responsible for the emptying of their garbage bins daily.
- h) Government to consider the installation of a flagpole for use in formal events.
- i) Vending permits to also restrict vending from the location on Public Holidays and Saturdays & Sundays with the exception that food and juice trucks, and local produce vendors can vend on Public Holidays, Saturdays, and Sundays.
- j) Vending permits shall be restricted whereby the vendor cannot operate during a national event

taking place at the Seven Mile Public Beach Park.

6 Vendor and Non –Vendors Applications

6.1 Powers of the Commission

The Commission may exercise any of the following powers at their discretion:

- a) The determination of applications and the steps to be followed are laid out in the Commission's Procedure and Policy Manual.
- b) The Commission reserves the right to evaluate applications in bulk or a case-by-case basis. The Commission reserves the right to issue licenses to multiple vendors operating in the same location on alternate times/days.
- c) The Commission reserves the right to deviate from or add vendors to any category as needed once an explanation or justification is recorded within the meeting minutes.
- d) All renewal application for a vendor permit at the same parcel of public land shall be subject to a ten-year maximum operation period irrespective of performance ratings to share the opportunity amongst other Caymanians and to prevent entitlement to the public land.
- e) Products Sold by Vendors should be pre-approved by the commission (include a complete list on the vendor application form). Offensive materials (i.e., ethnically or racially offensive) may not be sold or displayed. Failure to comply with this policy may result in termination of the Vendor Permit.
- f) Vendor hours of operations may be limited to support policy objectives.
- g) Deposits may be required for certain permit situations where permission is granted to operate from Crown owned property such as Kiosks for example. Deposits may be returned to a vendor dependent on the condition of the property at the end of the occupation period.

It is the vendor's responsibility to ensure their compliance with other relevant Cayman Islands legislation prior to conducting Trade or Business from this site.

6.2 The Commission also has the right to deny, suspend, revoke

The Commission is fully authorized to make decisions regarding all aspects of public land vendor operations. The Commission also has the right to deny, suspend, revoke any vendor or non-vendor permits where the vendor:

- a) Fails to comply with the PLC policies;
- b) Shares or sub-leases the vendor's licenses or location to another entity without prior written consent of the Commission;

- c) Has not complied or cannot comply with applicable license requirements, laws, or regulations concerning the sale or offering for sale of any goods or services;
- d) Proposes or engages in any use or activity that is prohibited by local laws;
- e) Is not consistently present at the location based on the schedule submitted with their application;
- f) Engages in conduct that proves to be illegal, violent, belligerent, unprofessional, obscene, lewd and lascivious, or otherwise a serious threat to the general health, safety or welfare of the public and/or PLC Inspectorate;
- g) Actions resulted in claims being filed against the Commission for damages or personal injuries as a result of actions or omissions of the vendor or any of their contractors, employees or persons under their control;
- h) Actions resulted in damage to public property or injuries to the public or the Public Lands Inspectorate;
- i) Has received an excessive amount of verifiable complaints from the public and other vendors related to the disruptive and/or dangerous way that person or entity conducts themselves on public land; or
- j) Fails significantly in any other area of managerial concern.

Where the Commission suspends or revokes a vendor's or non- vendor's permit a request may be submitted to the Chief Officer responsible for Lands within 30 days to conduct a review of the decisions and its particulars. After the close of the review, the Chief Officer or his delegate shall submit a report in writing to the Commission stating any objections, representations, and shall include relevant recommendations, if any, or its reason for not making any recommendation.

7 Food Handling Safety for Food Stalls and Food Carts

Any vendor permit related to a food stall or food cart shall require at a minimum:

- a) A basic food handling certificate for the applicant from the Department of Environmental Health.
- b) Either one portable sink with hands free water distribution per vender or at a minimum one portable sink with hands free water distribution per every two vendors.
- c) If cooking onsite the cooking surface such as grills should be cleaned by the vendor daily.

Additional oversight or inspections by the Department of Environmental Health may apply. Areas of interest include food preparation areas where particular attention is paid to adequate food preparation spaces, impervious surfaces, the ability to maintain a hygienic work environment, separate sinks based on function, and any other aspect deemed necessary.

8 Lifeguard Certification (inclusive of CPR/ First Aid)

Water sports vendors shall receive Lifeguard Certification (inclusive of CPR/ First Aid) from the Red Cross or other suitable organisation to operate at this site. Requirements to be crafted similar to the dive industry and additional policy advice maybe issued or changed as the Commission see fit.

Beach Gear vendors shall receive CPR/ First Aid) from the Red Cross or other suitable organisation to operate at this site.

9 Health and Massage Vendors

Certain professions such as a “Massage Therapist” are a protected title under the Health Practice Act (2021 Revision) and requires a licence under that Act prior to commencing business at this site. Other titles may also be protected and it is the vendor’s responsibility to ensure compliance with relevant Cayman Islands legislation.

10 Vendor Locations and Number of Intended Vendors

Vendor Category	Zone Allocation	Number of Vendors
Beach Lockers	Zone K1- Vendor Kiosks (South section next to sidewalk)	2 vendors
Beach Gear	Vending from Vendor Kiosks. (Assistants allowed for setup of equipment and wayfinding within North (BC 1) and South (BC 2) Beach Chair Zones)	4 vendors in North and 4 vendors in South
Watersports	Vending from Vendor Kiosks. (Assistants allowed for setup of equipment within North (WS 1) and South Watersports (WS 2) zones)	2 vendors
Beverages	Zone K1- Vendor Kiosks	2 vendors (at present)
Sundry and Cultural Wares	Zone K1- Vendor Kiosks	2 vendors (at present)
Beauty and Massage	Zone K1- Vendor Kiosks	2 vendors (at present)
Food and Juice Trucks	Zone FT- Food Trucks Area	8 vendors
Food Stalls and Food Carts	Zone FS- Food Stalls and Mini Farmer’s Market	4 vendors (or more as space allows)
Local Produce	Zone FS- Food Stalls and Mini Farmer’s Market	4 vendors (or more as space allows)

10.1 Vendor Kiosks

The vendor kiosk area is to be used as the point of interaction between vendors and the public for the sale of items and vending generally. The Commission may expand this area of interest based on the number of vendors desired in agreement with the government or authorize other areas of interest for commercial activity.

10.2 Current state of Kiosks

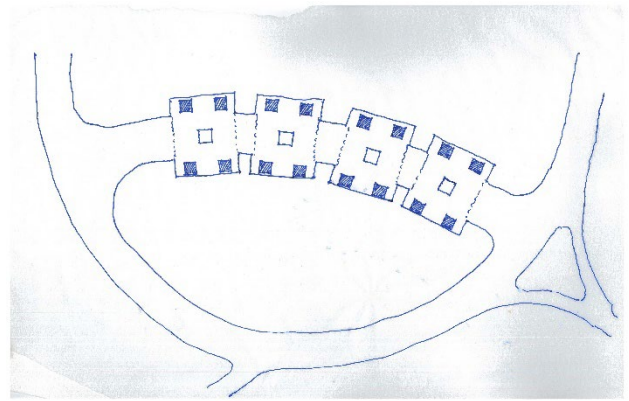



10.3 Items

- Trim overgrown vines.
- Level planter boxes with gravel to meet sidewalk and prevent a tripping hazard.
- Fix broken doors, locks, paneling of kiosk sides and roofs as needed.

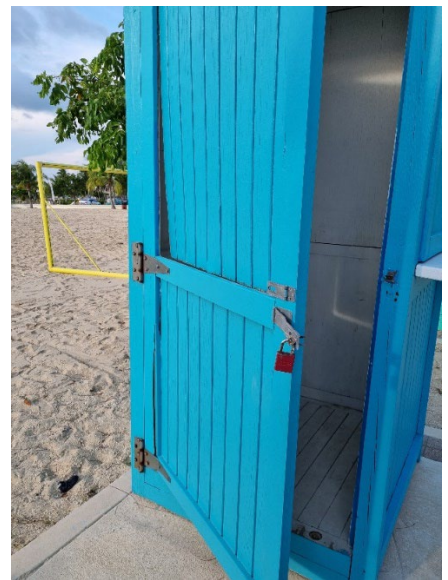

10.4 The Proposal

The presence of these very prominent colorful structures on site are be leveraged to promote an identifiable commercial area. They are very easy to find on site for visitors that are using the beach for their first time, and they are located along the most prominent entry and exit point for visitors. The huts also have electricity provisions adjoining each one and therefore are the best place to support a commercial center on site.



View looking south across the sand football pitch showing how identifiable these structures are.

10.5 Survey of Kiosk area

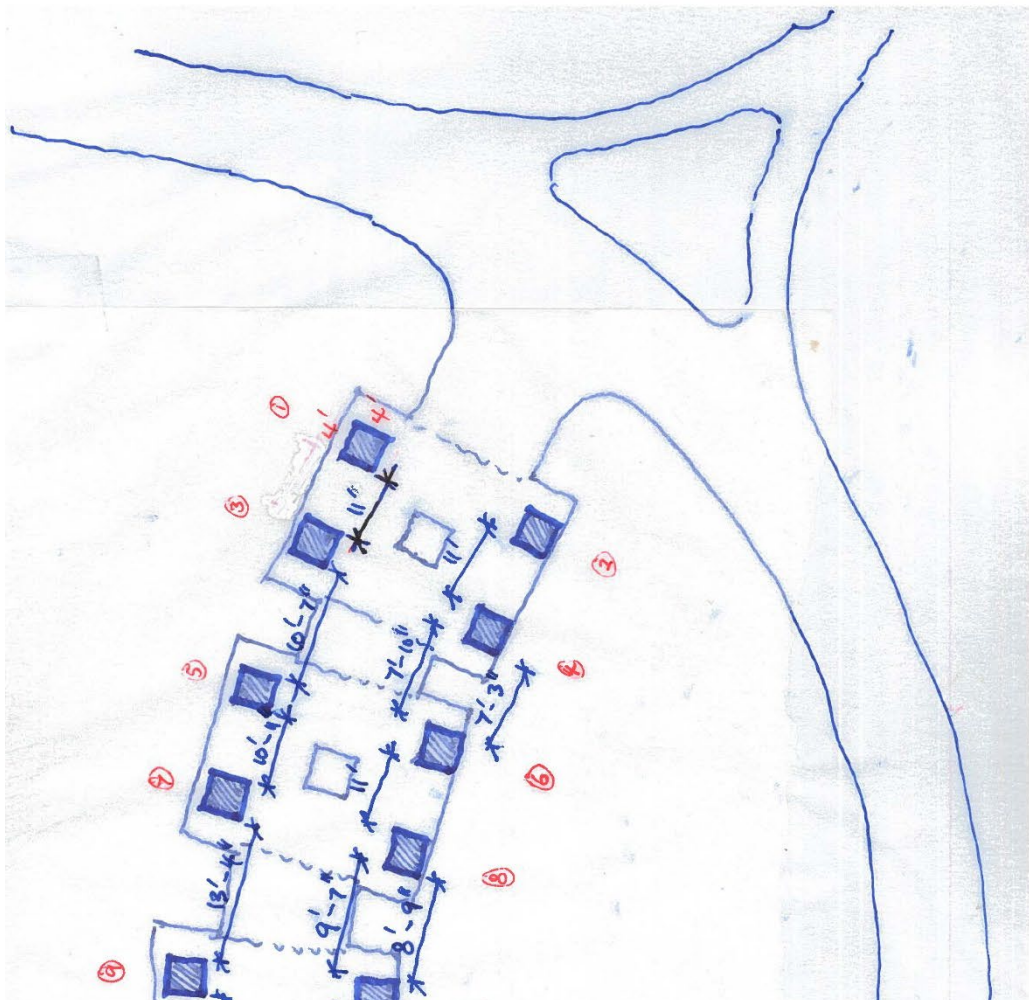

10.6 Allocation of collapsible tents based on space between kiosks.

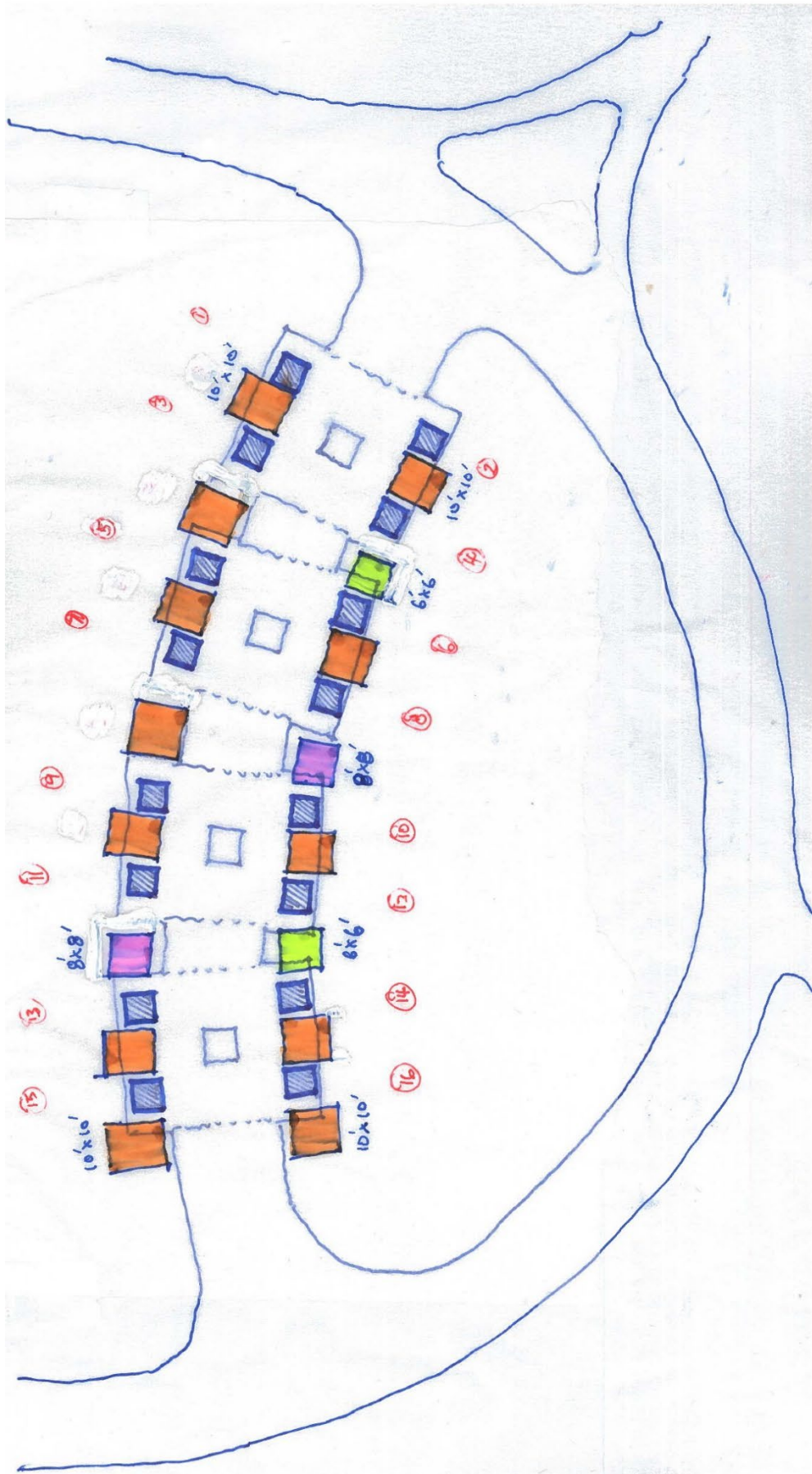

- 10.7** Tents must be collapsed each day at the close of operations and vacated from the site. The site is to be left clean and clear of obstructions. Vendor's adjoining kiosk maybe used as overnight storage, but the government will bear no risk of damages or loss. Vendors must take due care in storing heavy items. These items must be stored low and against the structure's base. No items are to rest against the structure's walls or exceed filling the structure greater than 4 feet high. All items should be removed prior to a pending storm event.
- 10.8** Example of folding tents allowed for use at this site in conjunction with the kiosks are shown below in a variety of sizes. Approval is only given for bright colours that are similar to colours or the sea (blues and greens), and white or cream colours.
- 10.9** Collapsible tents are not to be anchored to the kiosks. Anchor systems are allowed from the sand or floor to the collapsible tents only. These should be removable to prevent tripping hazards during non-operating hours. Further requirements may be specified.
- 10.10** Currently there are opportunity for the installation of a collapsible between each kiosk. It is envisioned that each kiosk will be paired with the adjoining space next to it for the setup of a collapsible tent. The spaces in between kiosk's allow for the setup of two (2) 6'x6' tents (shown in yellow on previous page), two (2) 8'x8' tents (shown in magenta on previous page) and twelve (12) 10'x10' tents (shown in orange on previous page).
- 10.11** Any signage to be integrated into a vendor's stall must be pre-approved. A- frame signage is desired. Sponsorship or use of branded products require pre-approval from the Commission.



6x6 Folding Tent



8x8 Folding Tent



10x10 Folding Tent

11 Food and Juice Trucks Area

The food truck area has been specifically located at the western end of the parking lot with 8 purpose-built spaces for food truck vendors.



12 Outdoor Food Court Area

The Outdoor Food Court area is the sandy area bound to the west by the low wall, which looks onto the sand football field and to the east by the food truck area. It is to be populated by at least 8 picnic tables with integrated sun umbrellas, 3 trash cans and at least 8 more shade trees such as sea grape, mahogany, birch, or a variety of poui trees, etc.



View looking south across the Outdoor Food Court Area.

13 Food Stalls, Food Carts and Local Produce

The currently unused area of grass to the south of the site is to be repurposed for the creation of a food stall and food cart area. This section is to host all collapsible tent vendors selling food or local produce to the public at large and will form the first installation of a street food experience for locals and visitors alike. The area is accessible along its entire length by the sidewalk running east to west and conveniently supports park and pickup food operations or the desire to eat in the nearby outdoor food court. Similarly, tourists are dropped off and picked up by bus in this area adjoining the sidewalk and therefore food vendors will have adequate foot traffic across their stalls.

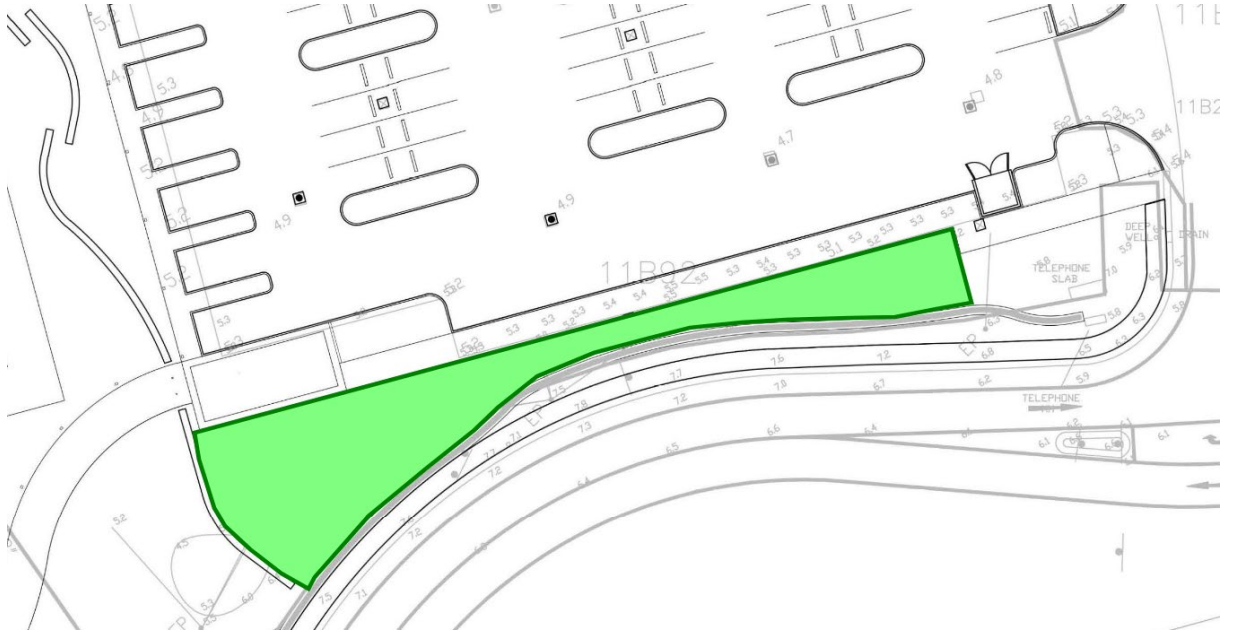

View looking east across Food Stalls, Food Carts and Local Produce



Electricity pole guide wires unfortunately cannot be removed at this time but the bases can be adequately fenced and integrated into the overall design.



View shows bus staging area for drop offs and pickups onto the sidewalk. Approved food stall vendors will not be allowed to occupy parking stalls or cabanas; all food stall operations are to be consolidated.

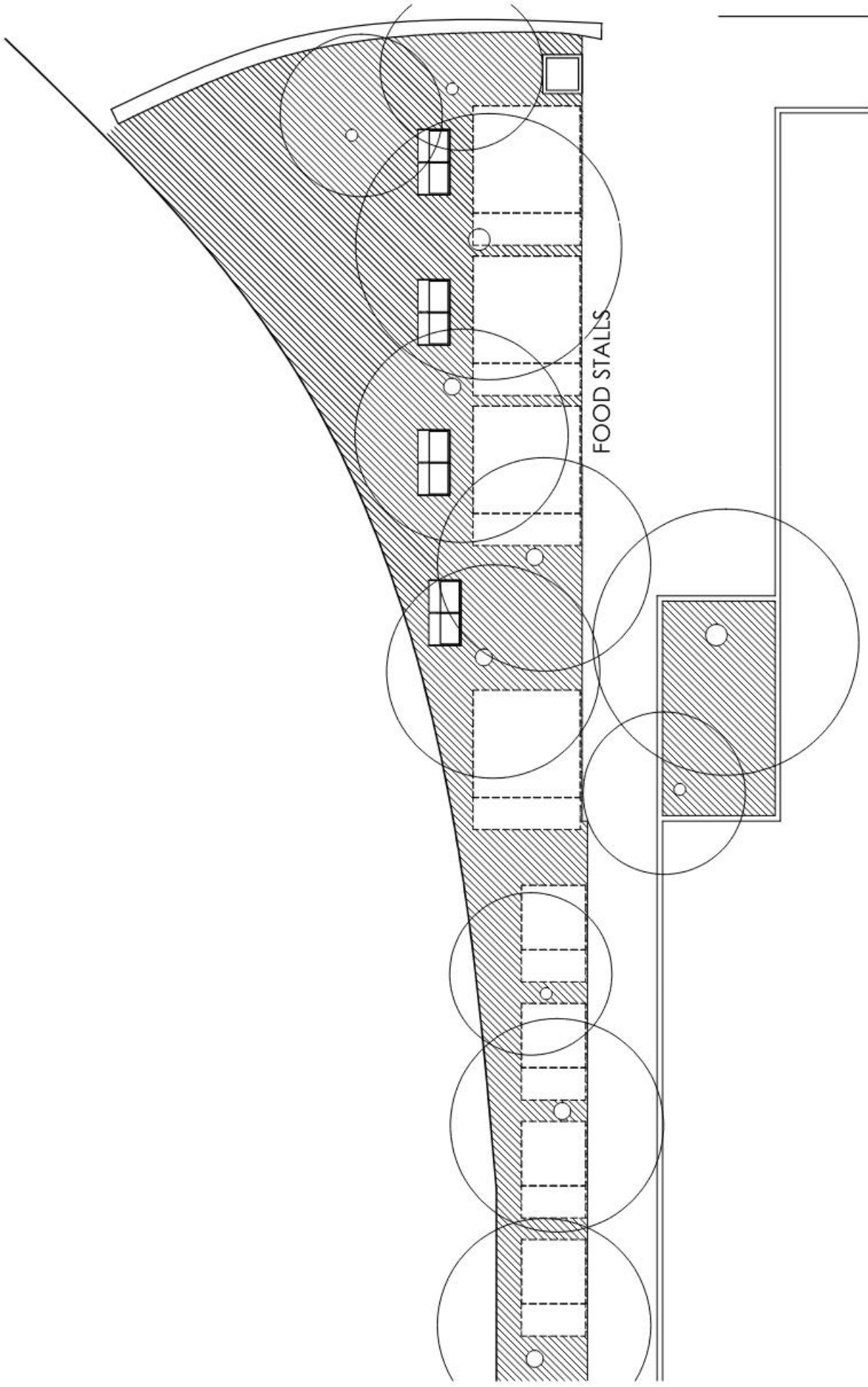

SITE PLAN - FOOD STALLS, CARTS AND LOCAL PRODUCE

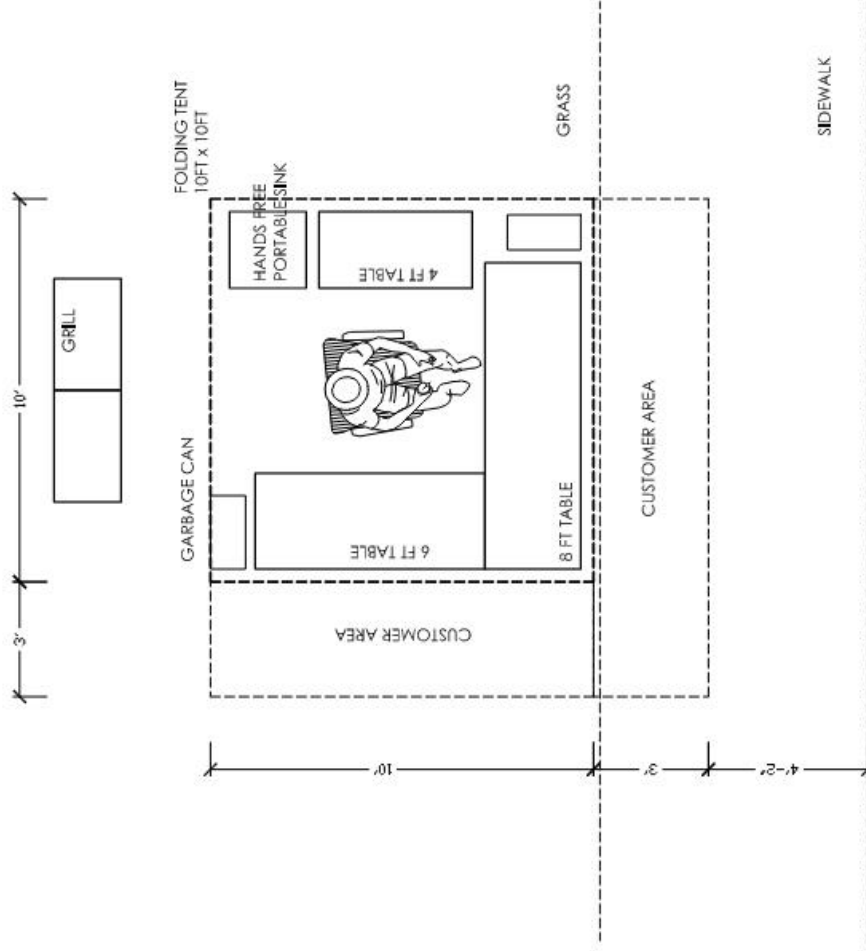

10'x10' COLLAPSABLE TENT OPTION

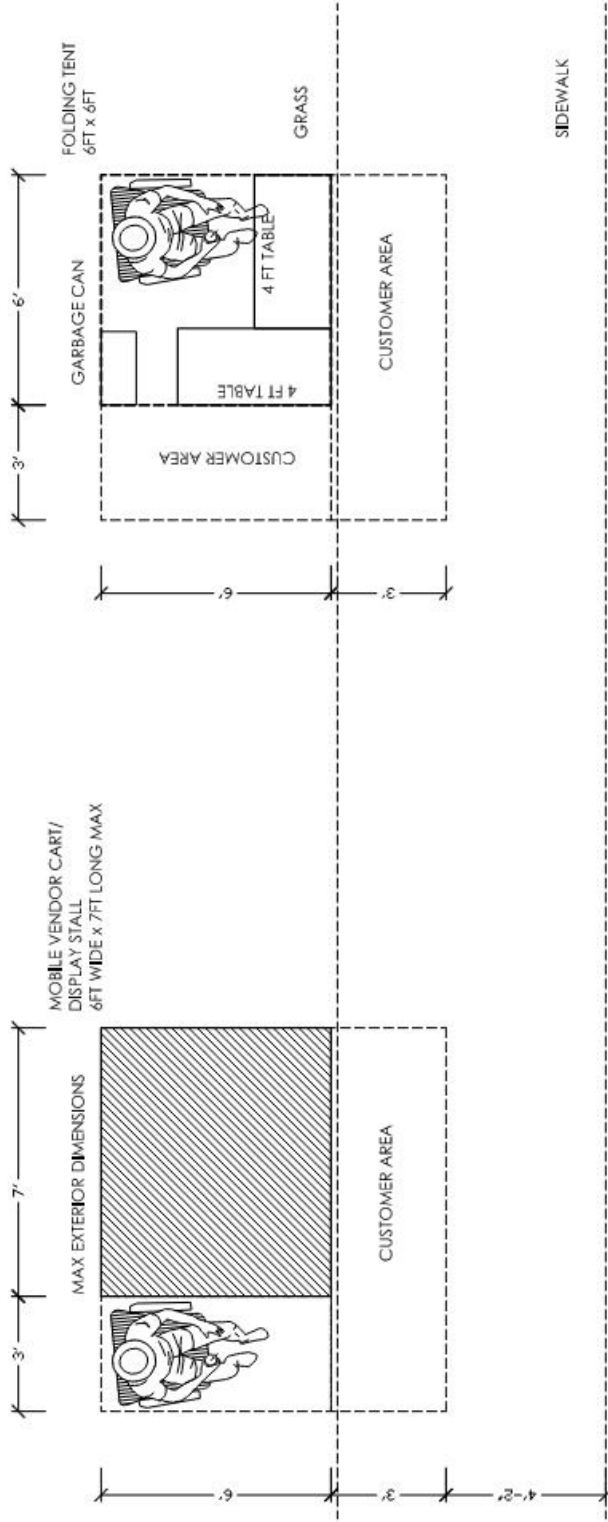

6'x6' COLLAPSABLE TENT AND CART OPTIONS

14 Beach Chair and Watersports vendors

This section will specify requirements for the Water Sports zones and the Beach Chair zones.

- WS 1** **North Watersports Zone**
- BC 1** **North Beach Chair Zone**
- BC 2** **South Beach Chair Zone**
- WS 2** **South Watersports Zone**

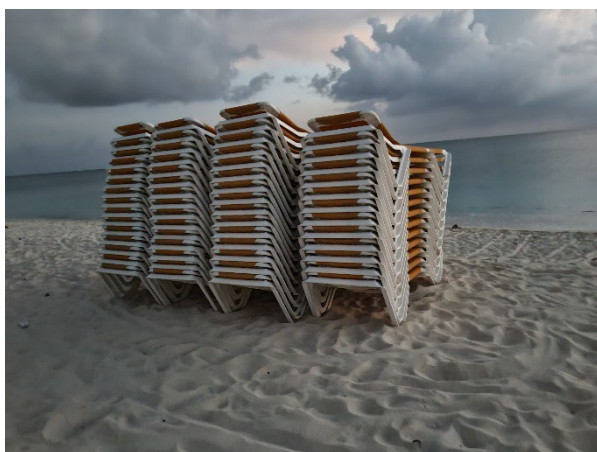

Views looking at the northern section of the beach. Stacked chairs are stored out in the open and can look unsightly if care is not taken. The adjoining volleyball court is close to the northern beach chair area and clear setback distances need to be maintained.



View of northern section of beach looking north (above) and south (directly above) at midday.



View of southern section of beach looking north and south from this position.



View of southern access point out to the beach and view of beach chairs and umbrellas layout.



View of beach chairs and umbrellas ready for rental and the current storage method for chairs after use.

14.1 The Proposal

It is the intention of government to organize the beach operations so that the largest most prominent section of the beach is left clear and available for use by Caymanians and other residents. During the week (i.e. excluding public holidays and weekends) beach chair vendors will be allowed to occupy certain sections of the beach for the provision of beach chairs but operations will have clear hours of operation. No beach chair operations are to occur on the weekends which are the prime use times for Caymanians and other residents.

The proposal also makes provision for adequate storage of the beach chairs in non-operation time periods in a manner that does not impede views out over the water once on the beach itself.

Specific areas of interest are:

- a) Water sport items that are very space intensive such as floating structures that occupy a lot of usable swim area will not be considered at this time.
- b) Any beach items that cannot be removed from the beach or stored in a suitable location daily (at the Commission's discretion) will not be considered at this time.
- c) Beach Gear vendors shall only occupy the space within their assigned beach chair vending areas.
- d) The public may setup personal beach chairs, umbrellas, etc. in the non-vending areas of the beach during vendor operating hours. During vending off hours inclusive of weekends the public may occupy any beach location with personal items while visiting the beach.
- e) Use of the public cabanas are to be avoided for vending purposes and these are to always remain accessible to the public except in accordance with occasional permits issued by the Commission.
- f) The Commission, in accordance with the policy set by the Cayman Islands Government will restrict all vendor permits issued for the site to allow operations on weekdays only (i.e. no operating on Public Holidays or weekends with the exception of Food & Juice Trucks and Local Produce vendors which will be allowed to operate on Public Holidays and Weekends).
- g) No vending from the location during national events at the location.

CONSTRUCTION NOTES

1. SAND FLOOR TO REMAIN
2. VERTICAL SUPPORTS CONSTRUCTED FROM 4"x4" PRESSURE TREATED WOOD POST WITH BASE BURIED 2 FEET DEEP INTO SAND. NOTE DOUBLE POST SUPPORTS AT OPEN END OF STRUCTURE. TAPER TOPS OF MEMBERS INWARD AND DOWNWARD AT A 30 DEGREE ANGLE TO PREVENT WATER SETTLING. SEAL WITH EXTERIOR GRAY SEALER, TWO COATS MINIMUM.
3. HORIZONTAL SUPPORT MEMBERS CONSTRUCTED FROM 2"x6" PRESSURE TREATED LUMBER. FASTEN WITH 3 INCH STAINLESS STEEL SCREWS TO VERTICAL POSTS. SEAL WITH EXTERIOR GRAY SEALER, TWO COATS MINIMUM.
4. VERTICAL PLANKING CONSTRUCTED FROM 1"x8" PRESSURE TREATED LUMBER. TAPER TOPS OF MEMBERS OUTWARD AND DOWNWARD AT A 30 DEGREE ANGLE TO PREVENT WATER SETTLING. FASTEN WITH 2 INCH STAINLESS STEEL SCREWS, 2 PER PLANK PER HORIZONTAL MEMBER. SEAL WITH EXTERIOR GRAY SEALER, TWO COATS MINIMUM.
5. BEACH UMBRELLA STORAGE BOX SHOULD HAVE A MINIMUM INTERNAL DIMENSIONS 52" L x 24" W 24"H. SIMILAR TO LIFETIME 60012 EXTRA LARGE DECK OX. 130 GALLON. EXTERNAL 60" L x 24"W x 26.3"H. INTERNAL 57.6" x 22.6"W x 23.4H.
6. STACK OF BEACH CHAIRS INDICATED IN HATCHED AREA. EACH STACK SHOULD HOLD 15 TO 20 CHAIRS DEPENDANT ON CHAIR TYPE.

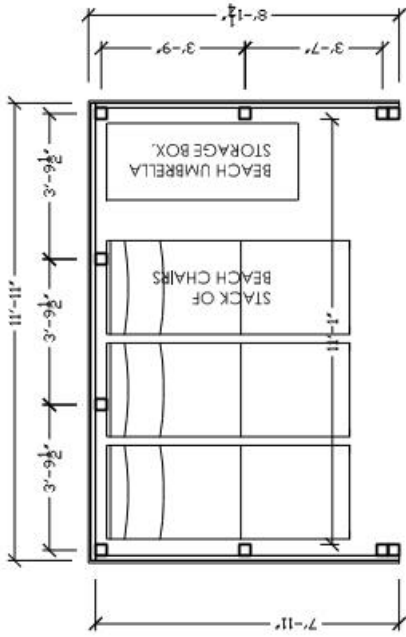

PLAN

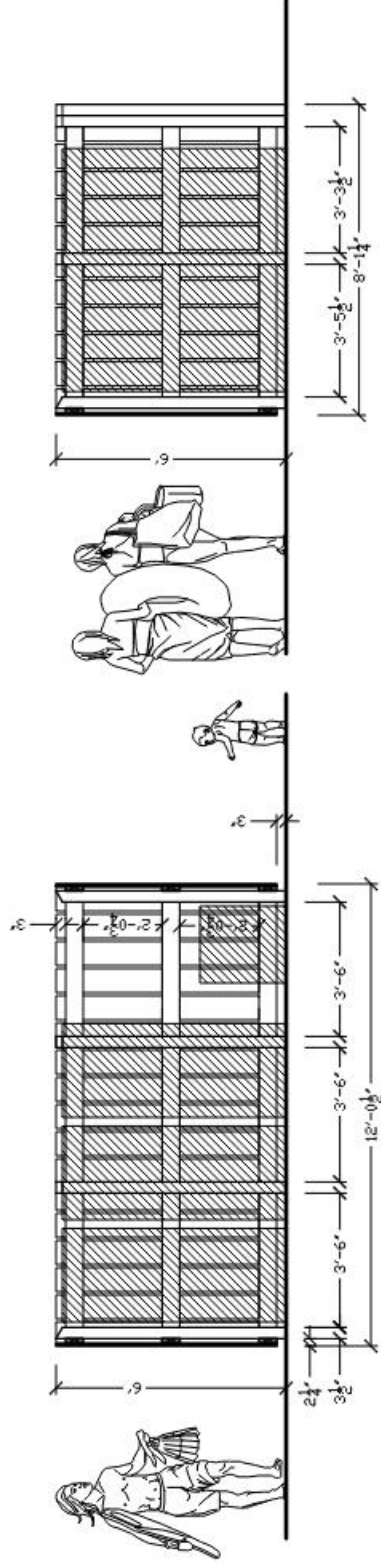

FRONT ELEVATION

CROSS SECTION

PROPOSED BEACH CHAIR BLIND DETAILS

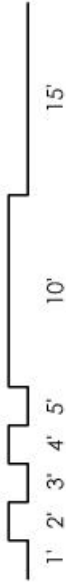

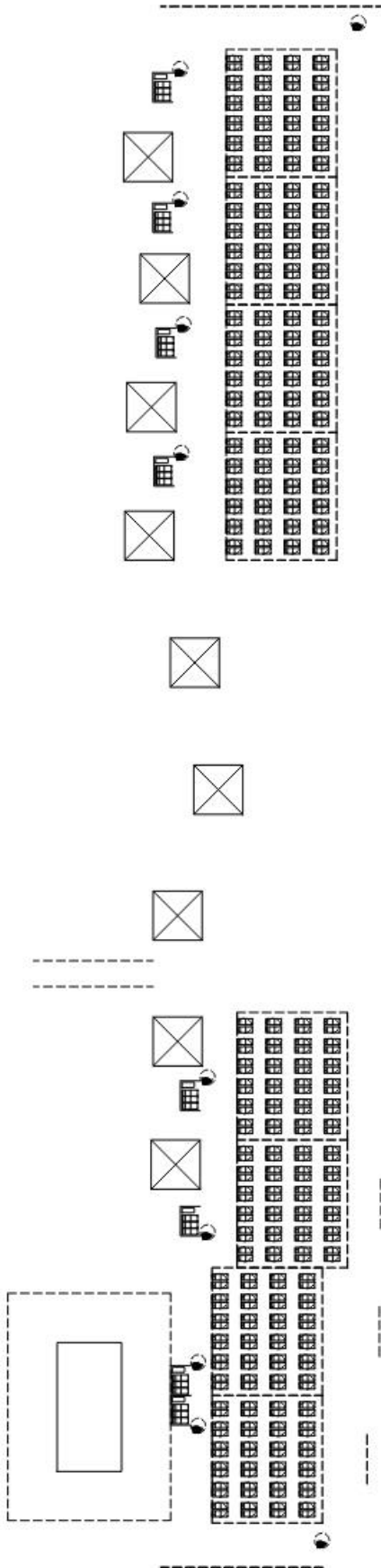

HIGHT BEACH CHAIR AREAS (48 CHAIRS PER VENDOR)

CH AIR AND SHORELINE POSITIONS ARE APPROXIMATED BASED ON SITE OBSERVATIONS IN SEPTEMBER 2022

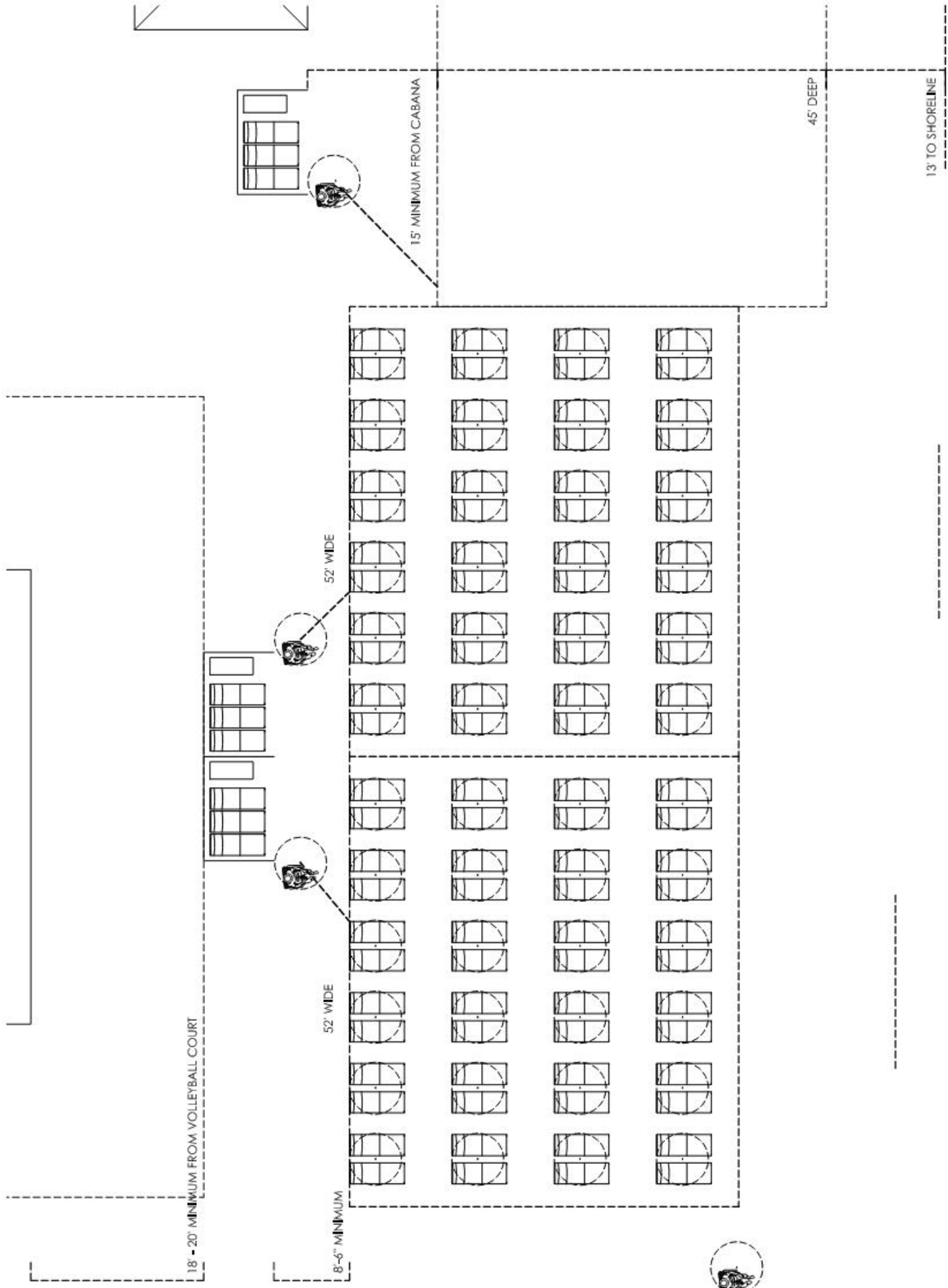

NORTHERN BEACH CHAIR AREAS (48 CHAIRS PER VENDOR)

CHAIR AREA AND SHORELINE POSITIONS ARE APPROXIMATED BASED ON SITE OBSERVATIONS IN SEPTEMBER 2022

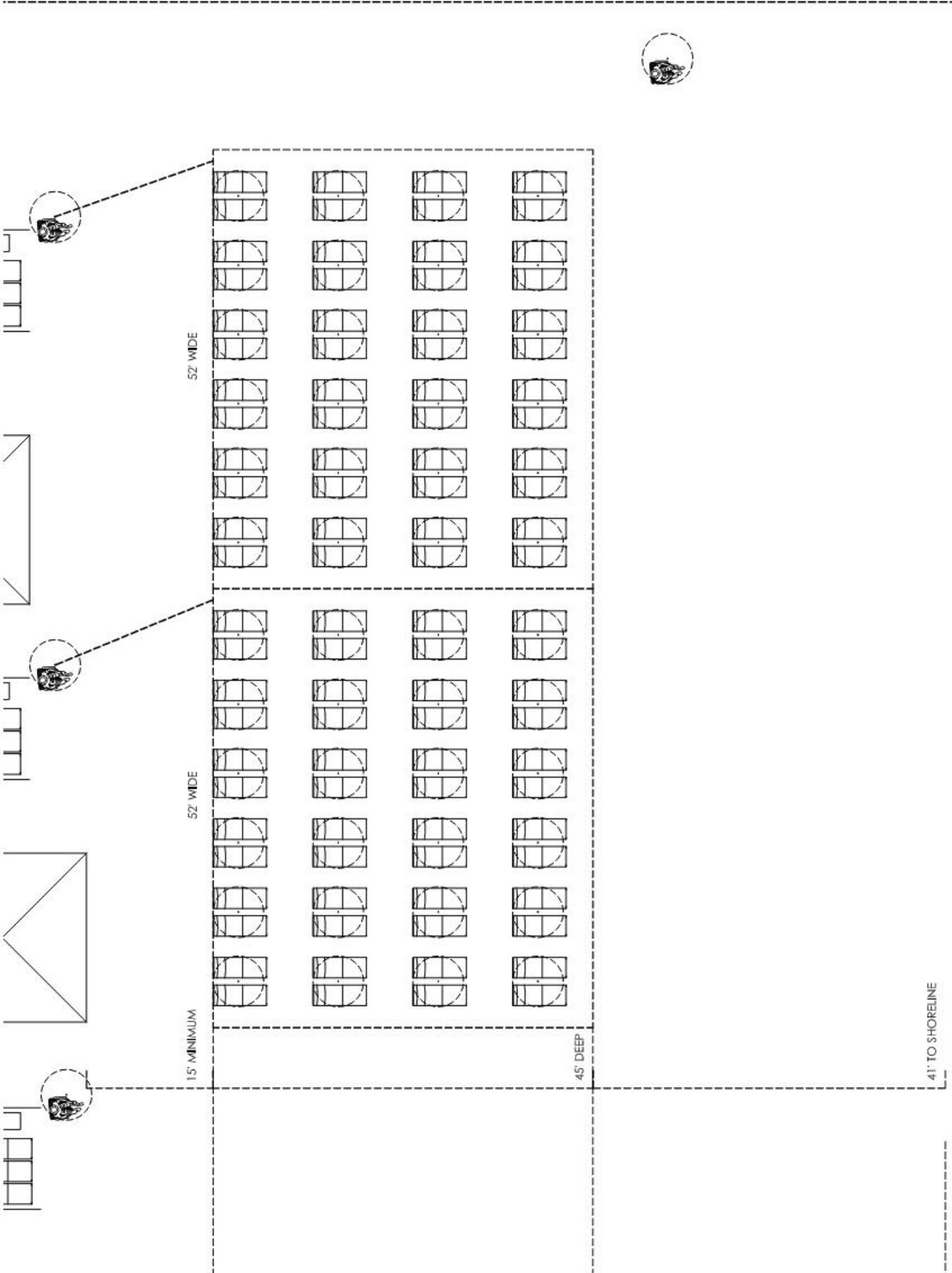

SOUTHERN BEACH CHAIR AREAS (48 CHAIRS PER VENDOR)

BEACH AREA AND SHORELINE POSITIONS ARE APPROXIMATED BASED ON SITE OBSERVATIONS IN SEPTEMBER 2022

15 Evaluation Criteria of Vendor Applications

New applications will be evaluated based on the criteria laid out below.

A. MANDATORY ELIGIBILITY REQUIREMENTS (for Vendors)

The following sets out the information requested to prove that an applicant can lawfully carry out the work. Information requested in this section will be assessed on a Pass/Fail basis.

Requested Information	Criteria for a Pass
Application Form (Appendix 1)	Each submission must include an Application Form fully completed and signed by the applicant.
Fee	Fees must be paid in full at time of application submission.
Business License	<p>If this site (location) is to be the sole or the first place of conducting business for a vendor, they should receive conditional permission to vend from this location in the first instance prior to receiving a Trade and Business License.</p> <p><i>Under Section 18 of the Trade and Business Licensing Act (2019 Revision) it states that “Where an applicant will be carrying on business in a public place, evidence of the approval of the relevant authority to carry on business in such a place” should be understood. Public Place includes a public beach (under section 2 of the Act).</i></p> <p>If the business conducts business from other locations the submissions should include a Cayman Islands Trade & Business License (TBL). Confirmation of the Cottage Industry exemption is not necessary in writing, but businesses are encouraged to make the Department of Commerce and Investment aware of their presence.</p> <p><u>Definition of Agriculture Products and Cottage Industry</u> <i>According to Section 3 (b) of the Trade and Business Licensing Act (2019 Revision), Caymanians who produce and sell agricultural products or cottage industry products, including, for example, jams, jellies, heavy cakes, sauces and thatch work; and any Caymanian who is self-employed and who creates for sale artistic, dramatic, musical or literary works are exempt from the TBL law.</i></p>
Micro Businesses	To promote and encourage small business development at this location, Micro Businesses and Cottage Industry applicants are to be considered.

	<p><u>Definition of Micro Business</u></p> <p><i>According to the Department of Commerce & Investment, Micro businesses are those that, among other conditions, employ up to four employees (excluding the owner), and have an annual gross revenue not exceeding CI\$250,000 in the preceding fiscal year.</i></p>
Business Ownership	Must be 100% Caymanian Ownership
Staff Configuration	Must be 100% Caymanian Staff
Food Safety Training	Food vendor applicants must complete food safety training provided by the Department of Environmental Health. A valid copy of the Food Handler's Certification must be included with submission.

B. CONDITIONAL REQUIREMENTS UPON APPROVAL

If approved a vendor must first receive a Trade and Business License or meet the definition of a cottage industry prior to conducting business from this site. Additionally, any vendor category specified below must also meet the specifications stated within 90 calendar days of approval subject to force majeure but may conduct business during this period. Failure to obtain any of these requirements may result in the Vendor's permit being suspended or revoked.

Requested Information	Criteria
Customer Service Training Certification	Proof of PRIDE training certification for each employee. (Relevant to all vendor categories)
Health and Safety Certifications	<ol style="list-style-type: none"> 1. Proof of Valid First-Aid/CPR/AED Certification for Beach Gear vendors and Water sports vendors. 2. Proof of Valid Lifeguard Certification for Watersports vendors.
Insurance	Appropriate insurance coverage commensurate with the nature and risk of the operations.
Signage	Signage should be pre-approved prior to use.

C. RATED CRITERIA

The following sets out the information requested to rank submissions by the criteria laid out in this section. Information requested in this section will be assessed on a point-based system.

Rated Criteria Scoring System

Applicant Experience

Applicant's experience delivering products/ services?	
Less than 1 Year Similar Experience	1 Points
1 – 2 Years Similar Experience	4 Points
3 – 4 Years Similar Experience	6 Points
5 or more Years Similar Experience	8 Points

Operating Schedule

Applicant's intended operations per week?	
1-2 Days per Week	Up to 2 Points
3-4 Days per Week	Up to 4 Points
5 Days per Week	Up to 6 Points

Product Mix

Applicant's product or service mix within a vendor category?	
Poor	Up to 2 Points
Common items	Up to 5 Points
Unique, Interesting, Positive Community Impact or benefit	Up to 15 Points

Cultural Relevance Product Mix

Cultural relevance of products/ services being offered within a vendor category?	
Little cultural relevance	Up to 2 Points
Moderate cultural relevance	Up to 5 Points
Experimental and may lead to new ideas or trends or Strong cultural resonance or ties to Caymanian Heritage	Up to 15 Points

Environmental Sustainability

How environmentally sustainable are the products for sale or rent? (e.g. use of environmentally friendly products, reducing food waste, minimizing use of plastics, etc.)	
Criteria	Points

Environmental Sustainability	No positive environmental impact	0
	Some positive environmental impacts	Up to 5
	Multiple positive environmental impacts	Up to 15

Renewal applications may consider the views of customers and the Public Lands Inspectorate.

Public Lands Inspectorate Feedback

The Public Lands Inspectorate is required to provide feedback on (renewal applications or past experiences) (completed at least annually)?		
Inspectorate Feedback	Observed Customer Service (residents, visitors, etc.)	Up to 10 points
	Attendance and presence at the location based on operating schedule	Poor (Up to 1 point), Good (Up to 5 points), Excellent (Up to 10 points)
	Compliance with local laws	Up to 10 points
	Necessary resources available for intended vendor category e.g., adequate beach chairs, beverages, etc.	Up to 10 points
	Any other Comments	Notes

Online feedback	Independent feedback from customers primarily (Caymanians, other residents, and visitors) (suggested as web-based feedback/ surveys, etc.)	Comments and feedback provided for review.
-----------------	--	--

Vendor Score Sheet - Summary

Requested Information	Description	Points
Applicant Experience	Applicant’s experience delivering products/ services?	
Operating Schedule	Applicant’s intended operations per week?	
Product Mix	Applicant’s product or service mix within a vendor category?	
Cultural Relevance	Cultural relevance of products/ services being offered within a vendor category?	

Product Mix		
Environmental Sustainability	How environmentally sustainable are the products for sale or rent? (e.g. use of environmentally friendly products, reducing food waste, minimizing use of plastics, etc.)	
Public Lands Inspectorate Feedback	The Public Lands Inspectorate is required to provide feedback on (renewal applications or past experiences) (completed at least annually)?	
Online feedback	Independent feedback from Caymanians, other residents, and visitors?	
Total		